

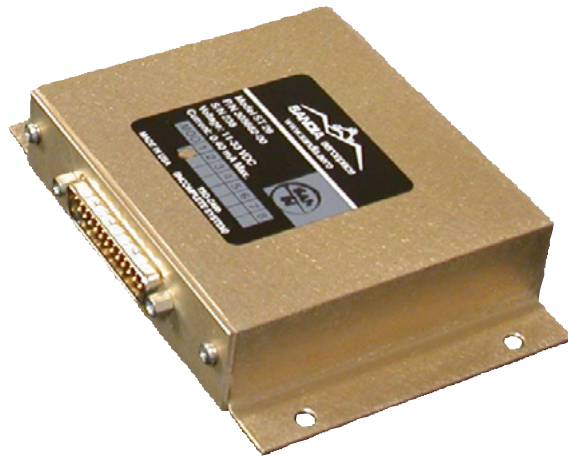

# ST 26

## Tach Generator Adapter



The document and the information contained herein is the proprietary data of SANDIA aerospace, Inc. No part of this document may be transmitted, reproduced or copied in any form or by any means without the prior written consent of SANDIA aerospace, Inc. Due to SANDIA aerospace's continued product and quality improvement programs, information contained in this document is the subject to change without prior notice. Copyright 2011 SANDIA aerospace, Inc. All rights reserved. Printed in USA

**RECORD OF REVISIONS**

Revision	Date	Description	Approval
A	20061208	DRN289	J. Fiala
B	20120625	ECN3915	L. Harrison
C	20130702	ECN3989	L. Harrison

**TABLE OF CONTENTS**

**Record of Revision ..... 1**

**Table of Contents..... 1**

**Section 1 General Description ..... 1**

**1.1 Introduction ..... 2**

**1.2 Product Description ..... 2**

**1.3 Technical Characteristics..... 2**

**1.3.1 Physical Characteristics..... 2**

**1.3.2 Operational Characteristics ..... 2**

**1.3.3 Approved Equipment..... 2**

**1.3.4 Certification ..... 4**

**Section 2 Installation Considerations..... 4**

**2.1 Introduction ..... 5**

**2.2 Mounting Considerations ..... 5**

**2.3 Cooling..... 5**

**Section 3 Installation Procedures ..... 6**

**3.1 General ..... 6**

**3.2 Equipment Required..... 6**

**3.2.1 Supplied..... 6**

**3.2.2 Required But Not Supplied ..... 6**

**3.3 Mounting..... 6**

**3.4 Electrical ..... 7**

**3.5 Operating Instructions and Limitations ..... 7**

**3.6 Calibration ..... 7**

**3.7 Continued Airworthiness..... 7**

**LIST OF ILLUSTRATIONS**

**Figure 1 ST26 Qualification Test Form..... 4**

**Figure 2 Dimensional Outline Drawing ..... 6**

**Figure 3 Interconnect Diagram ..... 7**

## SECTION 1 GENERAL DESCRIPTION

### 1.1 INTRODUCTION

This sheet describes the installation of the ST 26 Tach Generator Adapter. It is intended for use by FAA certified repair stations and original equipment manufacturers (OEM's) to install the ST 26 and includes both mechanical and electrical installation information. The installer should insure that the ST 26 is operating according to its intended function.

### 1.2 PRODUCT DESCRIPTION

The ST 26 is a Tach Generator Adapter that converts the sinusoidal output of Tach Generator to a digital format that can be used by aircraft display and/or control systems.

### 1.3 TECHNICAL CHARACTERISTICS

#### 1.3.1 PHYSICAL CHARACTERISTICS

Width 5.06" Height .99"  
Depth 3.35" Weight 0.5 lb

#### 1.3.2 OPERATIONAL CHARACTERISTICS

Operating Voltage 11-33Vdc  
Current .10 Amps per channel (.40 Amps total all channels)  
Operating Temp -55° C to +70°C  
Max Operating Altitude 55,000 Feet

#### 1.3.3 APPROVED EQUIPMENT

The ST 26 requires the following input from the on-board Tach Generator.

Signal: Sinusoidal

Signal Frequency Range: 4-100Hz  
Signal Amplitude Range: 4.25-150VPP

Approved Tachometers include:

Globe 22A703  
AAE 32005-007  
Electro-Mech EM-8001  
Mikrotechna LUN 1333.12-8

The ST 26 digital output signal is:

Pulled up collector to aircraft power  
Rise time is 15 uS nominal to Aircraft power @ 5VPP  
Fall time is 10uS nominal @ 5VPP  
Low voltage: 0.5VDC, 370 ohm  
High Voltage: Aircraft power through 4.7 K Ohm

Approved Systems include:

Garmin G900X, G1000 Integrated Avionics Systems

**NOMENCLATURE: TACH-GENERATOR ADAPTOR  
TYPE/MODEL/PART NO: ST 26/305662-[XX]**

**MANUFACTURER'S SPECIFICATION AND/OR OTHER APPLICABLE SPECIFICATION: 305662-00**

**MANUFACTURER: SANDIA AEROSPACE  
ADDRESS: 3700 OSUNA RD. NE, SUITE 711  
ALBUQUERQUE, NM 87109**

**REVISION & CHANGE NUMBER OF DO-160: REV E CHANGE -**

CONDITIONS	SECTION	DESCRIPTION OF TESTS CONDUCTED	NOTES:	
Temperature and Altitude	4.0	Tested to Category [A2F2X]	-65 Ground/-55 Short -55 Operating  +85 Ground/+70 Short +70 Operating	
Low Temperature	4.5.1 4.5.2			
High Temperature	4.5.3 4.5.4			
Loss of Cooling	4.5.5			Not applicable
Altitude	4.6.1			55,000 (2.69InHg),-1000FT
Decompression	4.6.2			55,000 Decompression
Overpressure	4.6.3	-15,000 (50.12InHg)		
Temperature Variation	5.0	Tested to Category B	5 deg/min	
Humidity	6.0	Tested to Category B	240 Hours / 10 Cycles	
Operational Shock and Crash Safety	7.0	Tested to Category B Aircraft Type 5 Test Type R	Helicopter and All Fixed-wing in random orientation	
Sustained Crash Safety	7.3.2	Tested to Category B, Centrifuge		
Vibration	8.0	Tested to Category (S) using vibration curves (B2M)	Fixed Wind Recip & Turboprop Mult over 12,500Lbs. Recip & Turbojet	
Explosion	9.0	Equipment identified as Category X, no test performed		
Waterproofness	10.0	Equipment identified as Category X, no test performed		
Fluids Susceptibility	11.0	Equipment identified as Category X, no test performed		
Sand and Dust	12.0	Equipment identified as Category X, no test performed		
Fungus	13.0	Equipment identified as Category X, no test performed		
Salt Spray	14.0	Equipment identified as Category X, no test performed		
Magnetic Effect	15.0	Tested to Category Z	Less than 0.3m deflection	
Power Input	16.0	Tested to Category Z	No Digital Circuits	
Voltage Spike	17.0	Tested to Category A		
Audio Frequency Susceptibility	18.0	Tested to Category Z		
Induced Signal Susceptibility	19.0	Tested to Category [ZC]		
Radio Frequency Susceptibility	20.0	Tested to Category [RR]	Note 1	
Radio Frequency Emission	21.0	Tested to Category M	Note 1	
Lightning Induced Transient Susceptibility	22.0	Tested to Category [Z3XXX]	Note 1, 2, 3	
Lightning Direct Effects	23.0	Equipment identified as Category X, no test performed		
Icing	24.0	Equipment identified as Category X, no test performed		
Electrostatic Discharge	25.0	Equipment identified as Category X, no test performed		
Fire, Flammability	26.0	Equipment identified as Category X, no test performed		

**Figure 1  
ST 26 Qualification Test Form**

Note 1: ST 26 is to be mounted flat, with mounting tabs on the reference ground plane. Bonding shall be close to mounting holes of case. Impedance from case to reference ground plane less than 2.5 milliohms. Test report shall describe actual bonding methods used.

Note 2: The following table defines the waveforms used on circuits

Pins/Circuits	Waveforms
1,2,4,5,7,8,10,11/ Tach Inputs	4, 5A - Level 4
13,25 / Acft Pwr	3, 4 - Level 3
15,18,21,24 / Output	3, 5A - Level 3

Output circuits (pins 15, 18, 21, 24) have 250 Ohm impedance between circuit and transient generator during waveform 5A testing.

Note 3: UUT shall be powered with 27.5Vdc +/- .25Vdc.

## ST 26

### Tach Generator Adapter

#### 1.3.4 CERTIFICATION

TSO C49B (Incomplete System)

ETSO C49B (Incomplete System)

DO 160E [(A2)(F2)X]BBB[(S)(B2M)]XXXXXXXXZZAZ[ZC][RR]M[Z3XXX]XXXX

“The conditions and test required for TSO approval of this article are minimum performance standards. It is the responsibility of those desiring to install the article either on or within a specific type or class of aircraft to demonstrate that the aircraft installation conditions are within the TSO standards. The article may be installed only if installation of the article is approved by the Administrator”

## SECTION 2 INSTALLATION CONSIDERATIONS

### 2.1 INTRODUCTION

The ST 26 has been designed to convert the sinusoidal output of approved Tach Generators to a digital output that can be used by onboard navigation systems. The ST 26 has four channels and can be used for both pro and engine tach interfaces.

### 2.2 MOUNTING CONSIDERATIONS

The ST 26 can be mounted in any axis either inside or outside the pressure vessel. To ensure protection against lightning strikes, the case should be grounded to airframe ground. This can be most easily accomplished by mounting the case on a grounded surface.

### 2.3 COOLING

The ST 26 does not require external Cooling

### SECTION 3 INSTALLATION PROCEDURES

#### 3.1 GENERAL

The ST 26 is supplied with a mounting connector and twenty-five crimp contacts. The ST 26 is mounted with four (4) number 6 or 8 screws.

#### 3.2 EQUIPMENT REQUIRED

##### 3.2.1 SUPPLIED

ST 26 System Includes:

ST 26	305662-00
Installation Kit	305663-00
Mating Connector/sockets	305720
Connector Clamp	305437

##### 3.2.2 REQUIRED BUT NOT SUPPLIED

Four (4) Number 6-32, 8-32 or equivalent mounting screws

#### 3.3 MOUNTING

The ST 26 mounts with four (4) number 6-32 or 8-32 or equivalent machine screws.

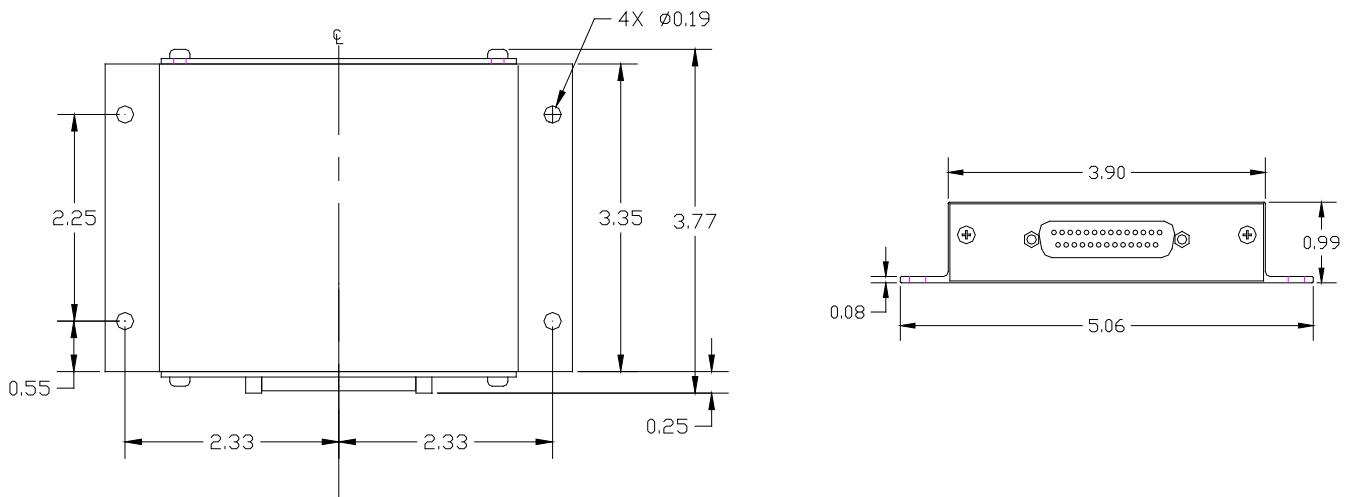

Figure 2  
Dimensional Drawing

ST 26  
Tach Generator Adapter

3.4 ELECTRICAL

The ST 26 operates on 11-33Vdc. Power to ST 26 should be protected by a 1.0 amp fuse or breaker. The ST 26 can be wired to use from one to four channels depending upon system interface requirements. All twisted pairs are #22 AWG.. Power and ground are single wires and should be #22 AWG or larger. Figure 2 shows the interconnect of the ST 26 to the Garmin system.

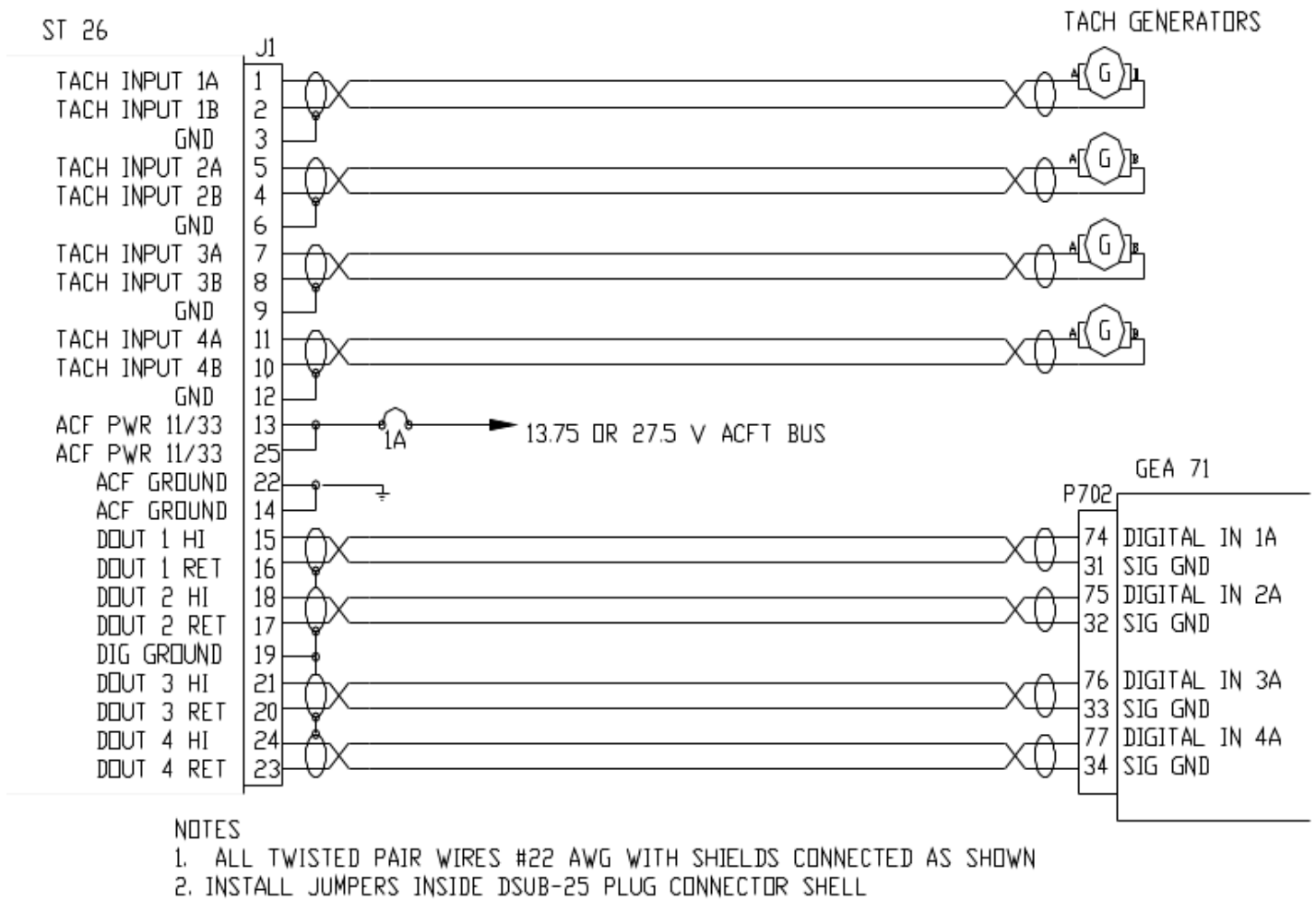

Figure 3  
Interconnect Diagram

3.5 OPERATING INSTRUCTIONS AND LIMITATIONS

Refer to the display unit(s) being interfaced for operation and limitations.

3.6 CALIBRATION

No Calibration of the ST 26 is Required

3.7 CONTINUED AIRWORTHINESS

Maintenance of the ST 26 is on condition only. No scheduled maintenance is required.